



Department of Provincial Education - NWP
Third Term Test - 2019

Grade 10

Science - I

Time: 1 hours

Name/ No.

• Answer all the questions.

- 01 Select the living substance from the substances given below.
(1) dry fire wood (2) germinating seed
(3) Coconut shell (4) Ice cube
- 02 The atomic number of potassium is 19. The electronic configuration of Potassium is,
(1) 2, 1 (2) 2, 8, 1 (3) 2, 8, 9 (4) 2, 8, 8, 1
- 03 Select the answer which only contains vector quantities.
(1) distance, speed, time (2) speed, velocity, time
(3) displacement, velocity, acceleration (4) speed, velocity, acceleration
- 04 Due to the deficiency of vitamin K,
(1) delays blood clotting (2) Occurs anaemia
(3) Occurs rickets (4) weakening of gum
- 05 Which answer given below denotes the Avogadro constant correctly?
(1) 6.022×10^{23} (2) 1.67×10^{-24}
(3) $6.022 \times 10^{23} \text{ mol}^{-1}$ (4) $1.67 \times 10^{-24} \text{ mol}^{-1}$
- 06 What is the unbalanced force acting on an object of mass 5Kg moving at an acceleration of 2ms^{-2} ?
(1) 2.5 N (2) 5 N (3) 7 N (4) 10 N
- 07 Select incorrect statement.
(1) Cell division occurs only in sexual reproduction
(2) the structural and functional unit of life is the cell.
(3) new cells are formed from pre-existing cells
(4) all organisms are made up of one or more cells.
- 08 Calculate the relative molecular mass of Ethyl alcohol. ($\text{C}_2\text{H}_5\text{OH}$) (H = 1, C = 12, O = 16)
(1) 34 (2) 46 (3) 60 (4) 62
- 09 The atmospheric pressure at the sea level is,
(1) 30 Hg cm (2) 60 Hg cm (3) 76 Hg cm (4) 86 Hg cm
- 10 Which is the correct way of starting the scientific name of coconut tree
(1) *Cocos Nucifera* (2) *Cocos nucifera*
(3) *cocos nucifera* (4) *COCOS nucifera*
- 11 Due to the polarization, water molecule.
(1) make intermolecular bonds (2) Polymerize
(3) make molecular lattice (4) make an ionic lattice
- 12 When move up from the sea level, the atmospheric pressure,
(1) increases gradually (2) decreases gradually
(3) not change (4) first increases, later decreases

13 Select the incorrect answer

Specific properties of water	The contribution for the maintenance of life
(1) Solvent property	for respiration of aquatic organisms
(2) Coolant property	for regulation of body temperature
(3) Cohesive and adhesive forces	for transportation of water to the upper parts of trees
(4) Differential expansion in freezing	for germination of seeds in cold regions

14 Which of the following answer denotes the dot and cross diagram of Ammonia molecule correctly?

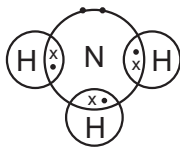

(1)

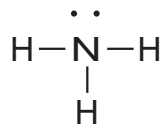

(2)

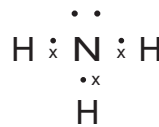

(3)

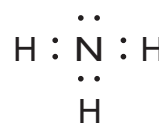

(4)

15 Several technical strategies used to facilitate work are shown below.

- (a) Hydraulic jack
- (b) Siphon
- (c) Hydraulic break system

Instance/ Instances where the liquid pressure transmission is applied,

- (1) Only a
- (2) Only b
- (3) Only a and b
- (4) Only a and C

16 Diagrams of several seeds are indicated below.



A



B



C



D

Which of the following answer correctly denotes their methods of dispersal?

	A	B	C	D
(1)	By wind	By wind	By water	By water
(2)	By wind	By animals	By water	By water
(3)	By wind	By animals	By wind	By water
(4)	By animals	By water	By wind	By wind

17 Select the answer which given correctly the uses of gases.

	Hydrogen	Oxygen	Carbon dioxide
(1)	as a fuel in rocketry	to give under water diverse	to make dry ice
(2)	to produce ammonia gas	to manufacture margarine	to extinguish fire
(3)	to make artificial rain	for combustion	to make artificial rain
(4)	to manufacture margarine from vegetable oil	for welding metal	to give space travellers

23 Several chemical reactions are given below.

- (a) $\text{CaO} + \text{H}_2\text{O} \rightarrow \text{Ca(OH)}_2$
- (b) $\text{Mg} + \text{CuSO}_4 \rightarrow \text{MgSO}_4 + \text{Cu}$
- (c) $\text{CaCl}_2 + \text{Na}_2\text{CO}_3 \rightarrow \text{CaCO}_3 + 2\text{NaCl}$

The correct answer which contains the types of the above reactions respectively.

- (1) Chemical combination, Chemical decomposition and Single displacement reactions.
- (2) Chemical combination, Single displacement reactions and double displacement reactions.
- (3) Chemical combination, double displacement reactions and Single displacement reactions.
- (4) Chemical combination, Single displacement reactions and double displacement reactions.

24 Several statements prepared by a group of students as regard to an instance of hanging a picture on the wall are given below.

- (a) The object is in equilibrium under a, b and c forces.
- (b) The resultant of forces a, b, and c is zero when an object is in equilibrium.
- (c) The sum of the forces a and b are equal to the force c.

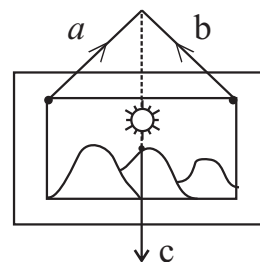

Correct answer

- (1) Only a
- (2) a and b only
- (3) b and c only
- (4) a, b, c all

25 Meiosis differs from mitosis,

- (1) because the daughter cell receives the same chromosomal number as the mother cell.
- (2) because two daughter cells result at the end of the cell division.
- (3) because four daughter cells result at the end of the cell division.
- (4) because takes place in both diploid and haploid cells.

26 A chemical reaction takes place in a blast furnace during extraction of iron is given below.

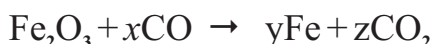

Values of x, y and z are respectively.

- (1) 2, 2 and 3
- (2) 2, 3 and 2
- (3) 2, 3 and 3
- (4) 3, 2 and 3

27 A diagram of an electrical circuit is given below.

When open the switch (off) of the circuit the reading of the voltmeter which is connected to the x y terminals is known as,

- (1) Conventional electric current
- (2) Electromotive force
- (3) Potential difference
- (4) Voltage

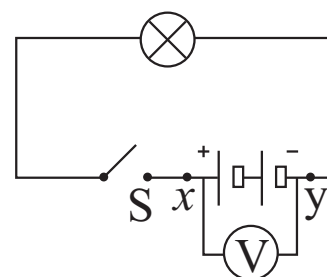

28 Several methods used for classifying organisms given below.

- (a) Three domain system of classification
- (b) Classification regarding dichotomous key
- (c) Five kingdoms of classification.

of the above, natural classification method/ methods,

- (1) Only a
- (2) Only a and b
- (3) Only a and c
- (4) Only b and c

29 The following setups are prepared to find out the factors affect for the rate of reactions.

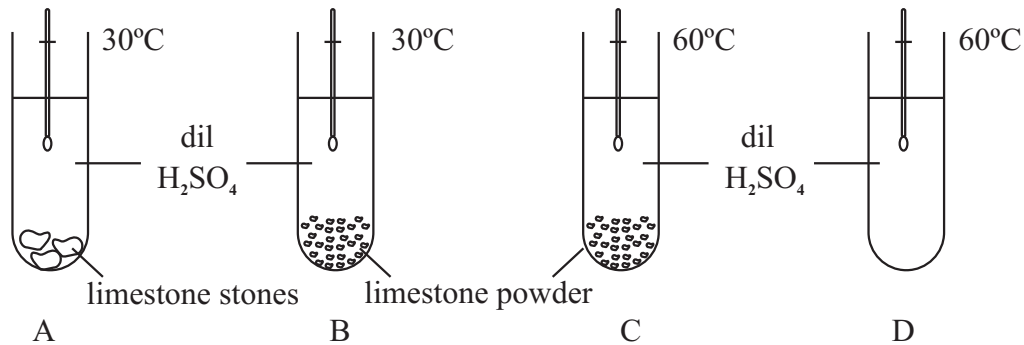

Pair of set ups suitable to find out the affect of the physical nature of reactants and the temperature for the rate of reactions respectively are,

- (1) AB and BC (2) AC and BC (3) AB and BD (4) AC and BD
- 30 What is the force which should be applied by the spring at B to exist the rod in equilibrium on knife edge X?

- (1) 30 N
 (2) 60 N
 (3) 120 N
 (4) 240 N

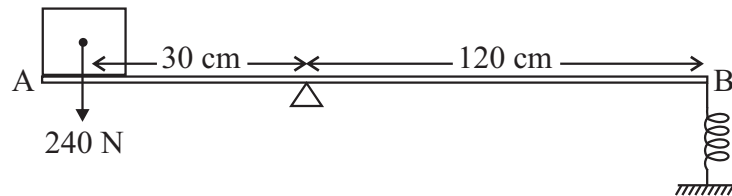

- 31 Given below are some statements presented by a group of students about genetic disorders.
- (a) Genes caused to genetic disorders are in recessive.
 (b) Some genetic disorders occur due to sex linked genes on sex chromosomes
 (c) Genetic disorders occur due to mutations in autosomal chromosomes.

Which of the above are correct regarding haemophilia and red green colour blindness?

- (1) a and b (2) b and c (3) a and c (4) a, b and c
- 32 Several chemical industries are given below.
- (a) Manufacturing Ammonia - Haber process
 (b) Extraction of salt - Saltern process
 (c) Manufacturing Sulphuric - Contact method

Industries which control the rate of reactions using catalysts are,

- (1) Only a (2) Only b and c (3) Only a and c (4) all a, b and c
- 33 The figure below shows a circuit connected with a dry cell to a bulb. The correct statement regarding the current flow across the bulb is,
- (1) The flow of electric current and the flow of electrons takes place towards the direction AB across the bulb.
 (2) The flow of electric current and the flow of electrons takes place towards the direction BA across the bulb.
 (3) The flow of electric current takes place to AB direction and the flow of electrons takes place to BA direction across the bulb
 (4) The flow of electric current takes place to BA direction and the flow of electrons takes place to AB direction across the bulb

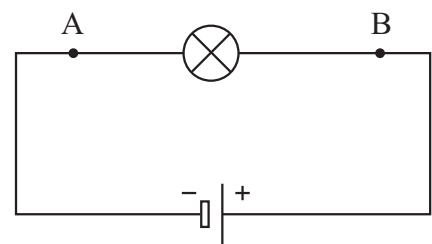

- 34 Given below are several instances of applying the knowledge of inheritance.
- Production of crops with high yield by hybridization of plants.
 - Production of Insulin by inserting a human gene into E - coli bacteria.
 - Production of golden rice enriched with vitamin A by inserting a gene obtained from carrot.

Instance/ Instances that apply the DNA technology,

- (1) Only a and b (2) Only b and c (3) Only a and c (4) all a, b, and c
- 35 The following diagram shows the way of connecting A, B and C identical torch bulbs to a circuit. The bulbs with the highest brightness and the lowest brightness are,

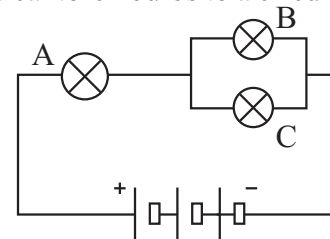

- A and B
 - B and A
 - B and C
 - C and A
- 36 Consider the information given below.

Metal	Way of exist in nature	Method of extraction
A	As the Oxide of metal	Reducing chemically
B	As the native metal	Physical extraction methods
C	As the chloride of the metal	Electrolysis of fused compound

The correct answer when preparing the above metals according to the descending order of their reactivity,

- (1) A, B and C (2) A, C and B (3) B, A and C (4) C, A and B
- The question number 37 and 38 are based on the following diagram.

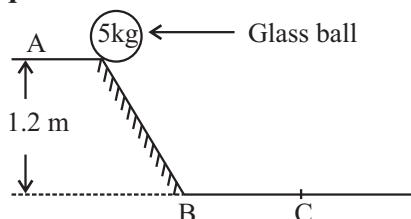

- 37 Find the potential energy when the glass ball of mass 5Kg is in the position A. ($g = 10\text{ms}^{-2}$)
- (1) 40 J (2) 45 J (3) 50 J (4) 60 J
- 38 When the glass ball come to the point C after sliding along the surface and if the kinetic energy of it is 40 J, What is the velocity of the object?
- (1) 4ms^{-1} (2) 8ms^{-1} (3) 16ms^{-1} (4) 32ms^{-1}
- 39 The experiment done by Gregor Mender about the transmission of inherited characteristics is important as students who studying science because you can.
- identify the possession of inherited characteristics of organisms.
 - identify the possession of contrasting characters.
 - Understand how to use the scientific method effectively.
 - Understand the pollination off pea plant naturally and artificially.
- 40 The marriage between blood relations is considered to be unsuitable. As a student who studying genetics, how do you explain this?
- It is believed that marriage between blood relations causes birth of deformed children. So, that marriage is not suitable.
 - The marriage between blood relatives causes recessive gene mutations to emerge and children born become deform. So, it is not suitable.
 - The marriage between blood relatives causes death of married couple.
 - The marriage between blood relatives does not cause conception, So that marriage is not suitable.



Department of Provincial Education - NWP
Third Term Test - 2019

Grade 10

Science - II

Time: 3 hours

Name/ No.

Instructions

- Write answers with clear handwriting
- Answer all questions in part A in the given space.
- Answer three questions from five questions in part B
- Submit both answer sheets A and B after attaching.

Part A - Structured Essay

01. A) Some seeds do not germinate, though there are all the factors required for seed germination. It is an adaptation shown by seeds for adverse environmental conditions.
- What is the term given to the above mentioned condition?
..... (1 mark)
 - Write 2 factors that affect for this condition.
..... (1 mark)
..... (1 mark)
 - Name the seeds where following methods are applied to avoid the above mentioned condition
Removing the seed coat (1 mark)
Burning the villi on the seed coat (1 mark)
- B) i. It is believed that Ipil Ipil seeds should be soak in hot water before germination what is the hypothesis that can be used in an experiment to test it?
..... (1 mark)
- What are the information that can be used in the experiment?
..... (1 mark)
..... (1 mark)
 - Write down the other two factors that should be kept constant.
..... (1 mark)
..... (1 mark)
- C) Seeds are disperse by water, wind and animals
- Write two seeds that are disperse by wind
..... (1 mark)
..... (1 mark)

- ii. Write two adaptations shown by seeds that are dispersed by water.
 - (1 mark)
 - (1 mark)
- iii. Seeds of Iluk are dispersed by wind. Write an adaptation shown by this plant.
 - (1 mark)

02. A) Following diagram depicts the inherited pattern of a monohybrid cross of pure breeding tall plants TT and pure breeding short plants tt of garden pea.

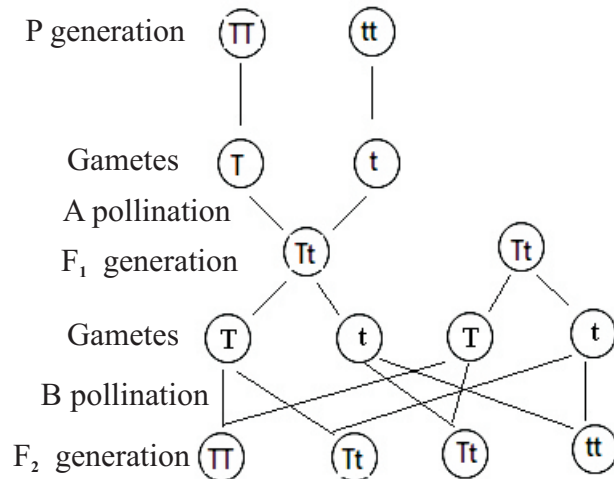

- i. What is the generation denoted by P?
 - (1 mark)
 - ii. Write a feature seen in F₁ generation.
 - (1 mark)
 - iii. Mention the methods of pollination indicated by letters A and B.
 - A (1 mark)
 - B (1 mark)
 - iv. Write the phenotype ratio of the F₂ generation
 - (1 mark)
- B) In a certain plant, the gene corresponding to round seeds is R and seed corresponding to wrinkled seeds is r.
- i. Write the genotypes for the following conditions of the above plant.
 - (a) Homozygous situation for round seeds (1 mark)
 - (b) Heterozygous situation for round seeds. (1 mark)
 - (c) Wrinkled seeds situation. (1 mark)
 - ii. Name the monomer of DNA molecule.
 - (1 mark)

C) Haemophilia is a disease which cause due to linked recessive gene. Recessive gene for haemophilia is h and dominant gene of the recessive gene for haemophilia is H

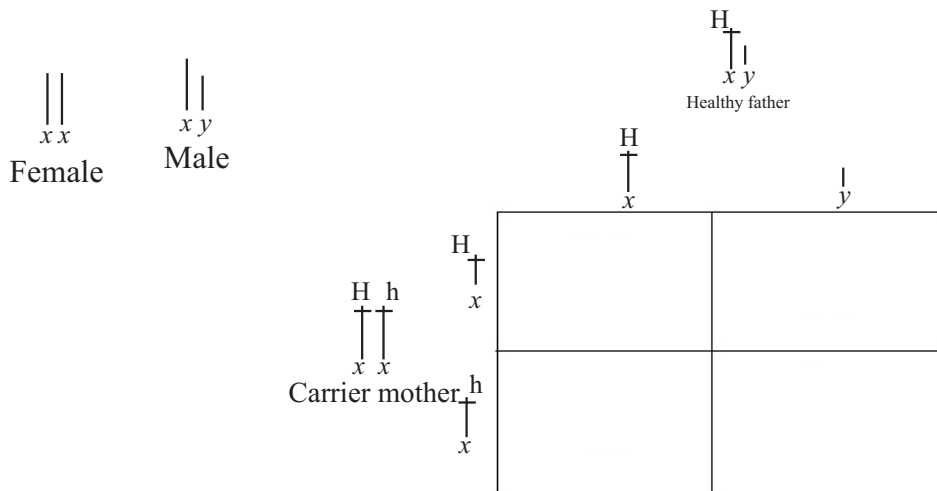

i. Complete the above punnet square. (4 mark)

ii. Write an example where genetic technology is used following fields.

(a) Agriculture (1 mark)

(b) Medical field (1 mark)

03. Following table shows information of a few elements.

Element	Atomic number	Relative molecular mass
H	1	1
C	6	12
N	7	14
O	8	16
Na	11	23
Cl	17	35.5

A) 20g of NaOH is dissolved in 1000ml of NaOH solution.

i. Find the molecular mass of NaOH
..... (1 mark)

ii. How many moles of NaOH is dissolved in 1000ml of the above solution?
..... (1 mark)

iii. How many moles of NaOH is dissolved in 250ml of the solution?
..... (1 mark)

- iv. What is the mass of NaOH to be dissolved in 250ml solution?
 (1 mark)
- v. Find the number of molecules of NaOH in (iv)
 (1 mark)
- B) i. Write the charge of the ion and electron configuration of the ion formed by following atoms
- (a) Na (1 mark)
- (b) Cl (1 mark)
- ii. What is the bond formed between Na ion and cl ion?
 (1 mark)
- iii. Write the molecular formula for the compound formed by C and H.
 (1 mark)
- iv. Name the bond formed in (iii) above.
 (1 mark)
- C) Following diagram shows the bond formed between two molecules of water.

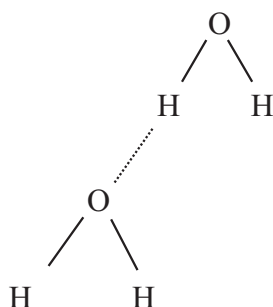

- i. What is the most electro negative atom from the atoms that form the water molecule?
 (1 mark)
- ii. Name the bond depicted by dotted lines.
 (1 mark)
- iii. What is the process that occurs in water molecule due to electro-negativity difference in atoms in formation of the bond you mentioned in (ii) above.
 (1 mark)
- iv. Write two special characteristics of water due to formation of those bonds.
 (1 mark)
-
-

04 Following set up is designed to demonstrate hydrostatic pressure.

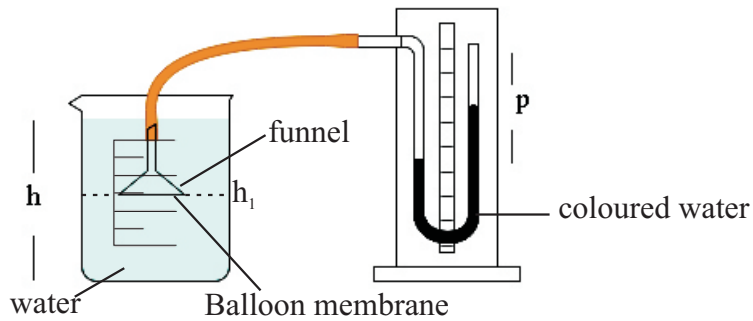

- i. If pressure inside water is $p = h\rho g$, write the two factors that is kept constant when doing the above experiment.
 (1 mark)
- ii. What can you observe when salt is added to water when funnel is at h_1 position?
 (1 mark)
- iii. Height of the water level of the beaker is 10cm. Density of water is 1000Kg m^{-3} and gravitational acceleration is 10ms^{-2} . Find the pressure at the bottom of the beaker.
 (1 mark)
- iv. Draw a rough sketch of the graph between depth of water level h and difference of coloured water level.

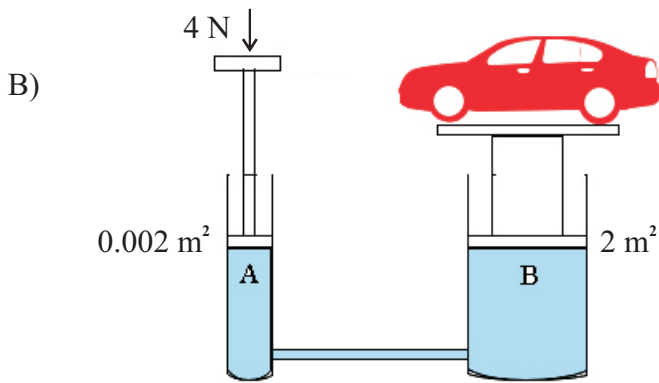
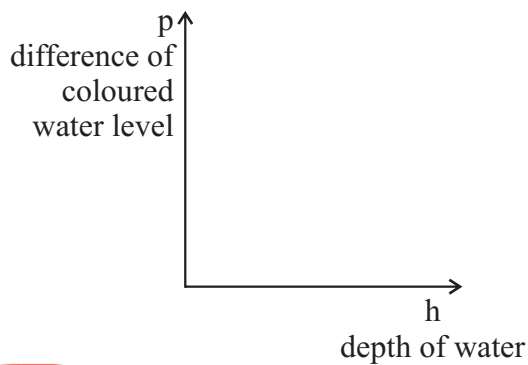

- i. Calculate the pressure created on A using, pressure = force/ cross sectional area.
 (1 mark)

- ii. Find the pressure created by B, if the cross sectional area of B is 2m^2
 (1 mark)
- iii. What is the name given to the above equipment?
 (1 mark)
- iv. Write an advantage of this pressure transmission method.
 (1 mark)
- v. Write an instance where this pressure transmission method is used.
 (1 mark)

C) Following activity was done to investigate the upthrust created by water.

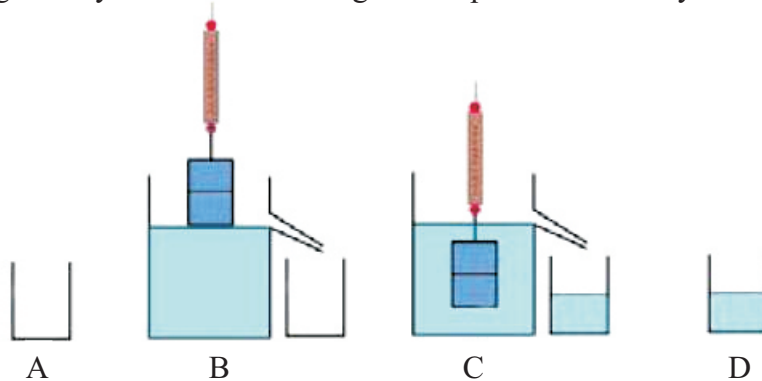

Weight of the empty beaker A = 0.6N

Reading of the B spring balance = 2.0 N

Reading of the C spring balance = ---- N

Weight of the beaker D with water = 1.4 N

- i. What is the weight of the displaced volume of water?
 (1 mark)
- ii. Find the value for the reading of spring balance C.
 (1 mark)
- iii. Using a rough sketch show the upthrust created on the object and weight of the object of situation C.
 (1 mark)
- iv. Calculate the upthrust created by water on the object.
 (1 mark)
- v. What is the conclusion that you can arrive at, using the readings obtained during the activity?
 (1 mark)

Part B - Essay

05. A) A certain biological process can be written using following chemical reaction.

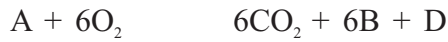

- i. Name the compound depicted by A
- ii. What is the biological process?
- iii. Write the chemical symbol for waste matter B.
- iv. What is the process of removal of B from the body?
- v. In which way does D is deposited in the tissues?

B) Following is an activity that is designed to identify protein as a biological molecule.

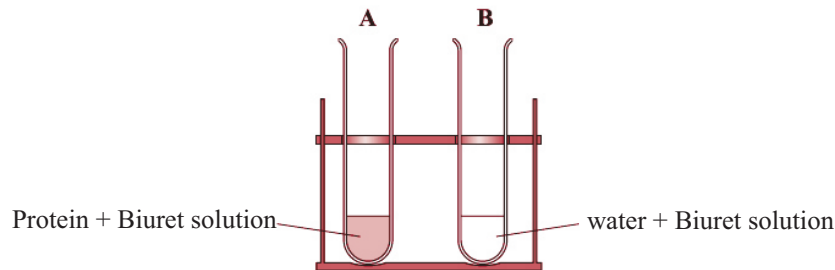

- i. Write the colour change that can be seen in A
- ii. What is the importance of B?
- iii. Name the main elements in protein.
- iv. Mention the building unit of protein
- v. Name the type of protein in bones.

C) Following diagram shows a part of female reproductive system.

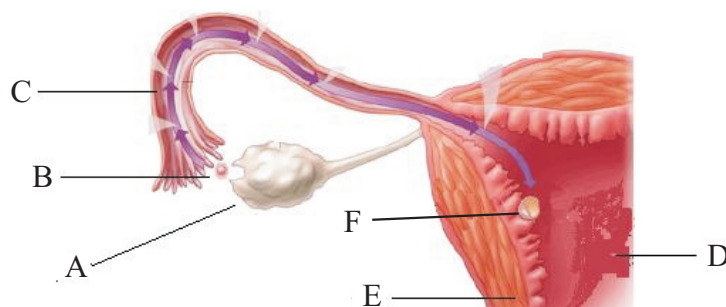

- i. Name A, B, C, D, E and F
- ii. In which part ova are produced?
- iii. In which part does the ovum fertilize with sperm?
- iv. By which name a fertilized ovum is known?
- v. Write two differences in B and F.

06. A) Same sized pieces of metals were added to equal amounts of salt solutions and were let them to react. According to the observations,

- i. Put the (✓) if the reaction occurs and put the (✗) if the reaction does not occur (copy the table to the paper)

Metal	salt of the metal				
	MgCl ₂	AlCl ₂	ZnCl ₂	FeSO ₄	CuSO ₄
Mg					
Al					
Zn					
Fe					
Cu					

- ii. According to the results, write the descending order of reactivity.
 iii. Write 2 observations that can be seen in CuSO₄ + Zn reaction.
 iv. Explain the reason for not occurring the reaction MgCl₂ + Al
 v. What is the metal out of Zn, Fe, Mg that will react faster with dil. HCl?
 vi. Write the balanced chemical equation for the reaction between Mg and dil. HCl.

B) Following setup is designed to produce a gas.

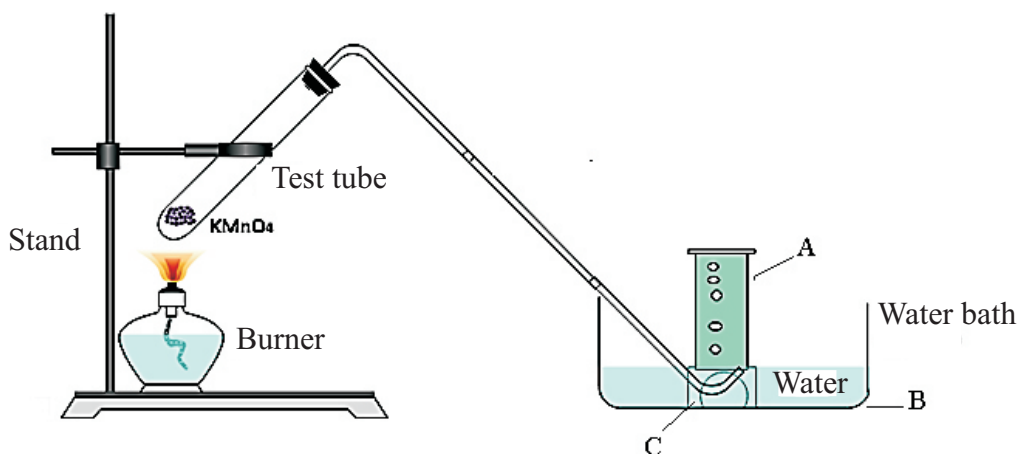

- i. Name A, B and C.
 ii. Name the gas released when heated.
 iii. To which type of chemical reaction, does the above reaction belongs?
 iv. Write a method to identify the released gas.
 v. What is the method of collecting gas through above setup?
 vi. Write an importance of the gas collected to the living beings.

07. A) A crane is carrying five cement bags weighing 50 Kg.

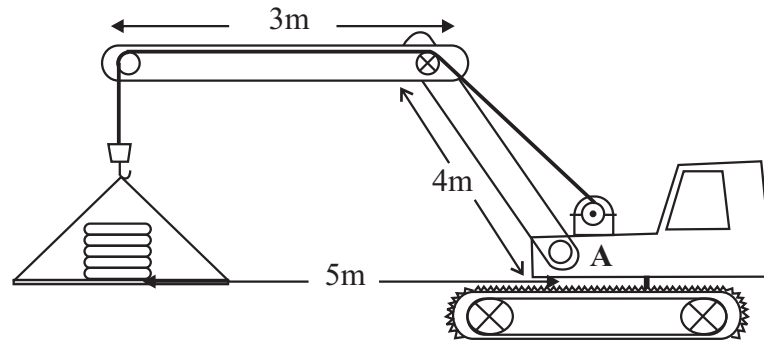

- i. Write the strategy used to increase the friction between the ground and crane.
- ii. Mention two simple machines used in the crane.
- iii. Write the special feature used in crane to minimize the pressure created on ground.
- iv. Find the force created downwards by cement bags.
- v. Find the moment of force created by cement bags around the point A

B. i. Mark the resultant force and its direction on the given diagram.



ii. Draw the resultant force of P and Q.

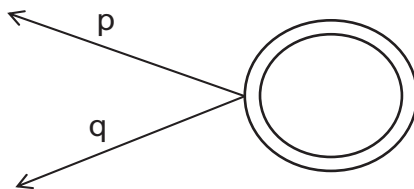

iii. Mark two collinear opposite forces that is acting on the following figure.

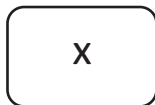

iv. Mention an instance where a large force is obtained by collection of several small forces.

08. A) i. Write the corresponding name of the animal for given features.

	Feature	Earthworm	Snail	Water lily	cockroach	Star fish
1	Multicellular, diploblastic, Radial, symmetry, aquatic					
2	Multicellular, triploblastic, Body is divided into segments internally and externally.					
3	Multicellular, coelomic, possess jointed limbs.					
4	Multicellular, triploblastic, soft bodied					
5	Triploblastic, coelomic, distributed water, vascular system, radial symmetry					

- ii. State the main phyla of above animals.
- iii. Name two phyla in which animals show sexual dimorphism.
- iv. Name an animal that live attached to aa surface.
- v. Name an animal with CaCO_3 shells

B) The circuit is designed to prove ohm's law.

- i. Explain the relationship between the current and potential difference.
- ii. Find the current that should sent through the resistor to show 5V potential difference.
- iii. What is the factor that should be kept constant at that instance?
- iv. Draw the above circuit using the standard symbols.
- v. Find the equivalent resistance of the following resistors.

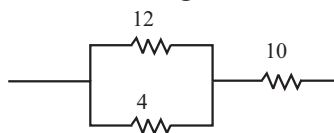
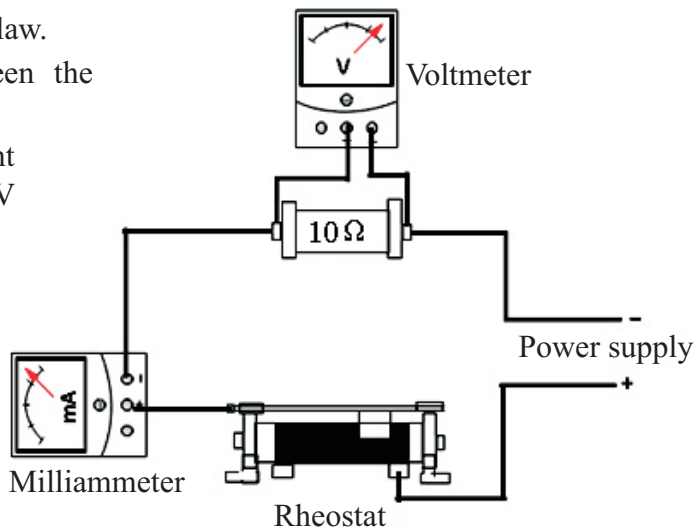

09. A) The figure shows the velocity graph of a moving object.

- i. Calculate the acceleration within first 5 seconds.
- ii. Find the total displacement of the object.
- iii. Calculate the average speed of the object
- iv. Describe the motion of the object within first 5 - 10 seconds.

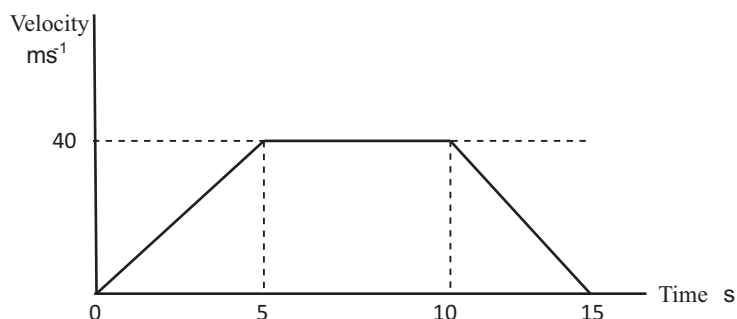

B) Information of three elements of the periodic table are given below.

X is a light gas with three isotopes

Y is an atom in which, 4 electrons are present in the outer shell. And it helps in making of diamonds, which is a hardest substance.

Z is a gas which turns blue litmus to colourless.

- i. Explain about the position of Y in the periodic table
- ii. Mention the valency of each of the above elements.
- iii. Mention the three isotopes of X
- iv. What is the bond formed between Na metal and Z gas?
- v. State the nature of the bond between Y and X.



Third Term Test 2019

Science I

Grade 10

Question Number	Answer	Question Number	Answer	Question Number	Answer	Question Number	Answer
1	2	11	1	21	4	31	1
2	4	12	2	22	1	32	3
3	3	13	4	23	4	33	4
4	1	14	3	24	2	34	2
5	3	15	4	25	3	35	1
6	4	16	3	26	4	36	4
7	1	17	1	27	2	37	4
8	2	18	2	28	3	38	1
9	3	19	1	29	1	39	3
10	2	20	3	30	2	40	2

Science II

Part A Structured Essay

01					
A	i	Dormancy of seed	01		
	ii	Embryo being not matured. Impermeability of testa for water or oxygen	01		
	iii	Orange / teak	01		
B	i	Keeping the seeds in hot water.	01		
	ii	Germination percentage of seeds kept in hot water. Germination percentage of seeds not kept in hot water	01		
C	i	Ware (Milk weed) Hora	01 01		
	ii	Having porous or fibrous pericarp possess pericarps that are suit for floatation	01		
	iii	Seeds being very light	01		
02					
A	i	Parental generation	01		
	ii	tall plants	01		
	iii	A - self pollination B - Cross polination	01 01		
	iv	tall 3 : short 1	01		
B	i	(a) RR (b) Rr (c) rr	01		
	ii	Deoxy ribo nucleotide	01		
C	i	<table border="1" style="display: inline-table; vertical-align: middle;"> <tr> <td style="width: 40px; height: 20px;"></td> <td style="width: 40px; height: 20px;"></td> </tr> </table>			01
	ii	a) Produce weedicide resistant crops pets resistant crops or any suitable answer. b) Insulin, growth hormone, making antibiotics or suitable answer.	02 02		

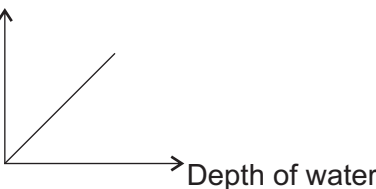
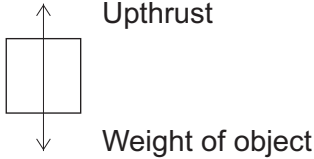
03			
A	i	$23 + 16 + 1 = 40$	01
	ii	$20/40 = 0.5$	01
	iii	$0.5/1000 \times 250 = 0.125$	01
	iv	$20/4 = 5\text{g}$ or $40 \times 0.125 = 5\text{g}$	01
	v	$0.125 \times 6.022 \times 10^{23} = 7.5275 \times 10^{22}$	01
B	i	(a) Na^+ - 2 , 8 (b) Cl^- - 2 , 8 , 8	01 01
	ii	Ionic	01
	iii	CH_4	01
	iv	Covalent	01
C	i	-O	01
	ii	Intermolecular bonds	01
	iii	Polarization	01
	iv	Increase the boiling point of water	01
04			
A	i	Density, Gravitational acceleration	01
	ii	Coloured water level goes up	01
	iii	$10/100\text{m} \times 1000\text{m}^{-3} \times 10\text{ms}^{-2} = 1000\text{Nm}^{-2}$	01
	iv	Pressure  Depth of water	01
B	i	$4\text{N}/0.002\text{m}^2 = 2000\text{Nm}^{-2}$	02
	ii	$2000\text{Nm}^{-2} \times 2 = 4000\text{Nm}^{-2}$	01
	iii	Hydraulic jack	01
	iv	By applying a small force a large work can be done	01
	v	Vehicle break system or other suitable answer.	01
C	i	$1.4\text{N} - 0.6\text{N} = 0.8\text{N}$	01
	ii	$2.0\text{N} - 0.8\text{N} = 1.2\text{N}$	01
	iii		01
	iv	0.8N	01

Part B - Essay

05			
A	i	$\text{C}_6\text{H}_{12}\text{O}_6$	01
	ii	Cellular respiration	01
	iii	H_2O	01
	iv	Excretion	01
	v	ATP	01

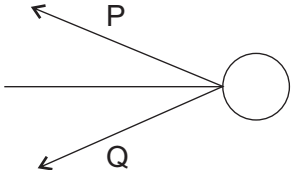
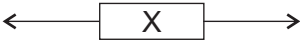
B	i	Dark purple	01																																									
	ii	Control experiment	01																																									
	iii	C , H , O , N	01																																									
	iv	Amino acid	01																																									
C	i	a - Ovary b - ovum c - Fallopian tube d - Uterus e - wall of uterus	01																																									
	ii	Ovary	01																																									
	iii	Fallopian tube	01																																									
	iv	Zygote	01																																									
	v	Chromosomes of B - n Chromosomes of F - 2n	02																																									
06																																												
A	i	<table border="1"> <thead> <tr> <th rowspan="2">Metal</th> <th colspan="5">Metallic salts</th> </tr> <tr> <th>mgcl₂</th> <th>Alcl₂</th> <th>Zncl₂</th> <th>FeSo₄</th> <th>CuSO₄</th> </tr> </thead> <tbody> <tr> <td>mg</td> <td>x</td> <td>✓</td> <td>✓</td> <td>✓</td> <td>✓</td> </tr> <tr> <td>Al</td> <td>x</td> <td>x</td> <td>✓</td> <td>✓</td> <td>✓</td> </tr> <tr> <td>Zn</td> <td>x</td> <td>x</td> <td>x</td> <td>✓</td> <td>✓</td> </tr> <tr> <td>Fe</td> <td>x</td> <td>x</td> <td>x</td> <td>x</td> <td>✓</td> </tr> <tr> <td>Cu</td> <td>x</td> <td>x</td> <td>x</td> <td>x</td> <td>x</td> </tr> </tbody> </table>	Metal	Metallic salts					mgcl ₂	Alcl ₂	Zncl ₂	FeSo ₄	CuSO ₄	mg	x	✓	✓	✓	✓	Al	x	x	✓	✓	✓	Zn	x	x	x	✓	✓	Fe	x	x	x	x	✓	Cu	x	x	x	x	x	05
Metal	Metallic salts																																											
	mgcl ₂	Alcl ₂	Zncl ₂	FeSo ₄	CuSO ₄																																							
mg	x	✓	✓	✓	✓																																							
Al	x	x	✓	✓	✓																																							
Zn	x	x	x	✓	✓																																							
Fe	x	x	x	x	✓																																							
Cu	x	x	x	x	x																																							
	ii	Mg , Al , Zn , F , Cu	02																																									
	iii	Blue colour gradually decreases form a precipitate.	01																																									
	iv	The reactivity of Mg is higher than Al	01																																									
	v	Mg	01																																									
	vi	$Mg_{(s)} + 2HCl_{(aq)} \rightarrow MgCl_{2(aq)} + H_{2(ia)}$	02																																									
B	i	A - Gas jar B - Delivery tube C - beehive shelf	03																																									
	ii	Oxygen	01																																									
	iii	Decomposition	01																																									
	iv	introduce a glacing splint	01																																									
	v	downward displacement of water	01																																									
	vi	For respiration	01																																									
07																																												
A	i	Using belt	02																																									
	ii	Pulleys , Levers	02																																									
	iii	Increasing the contact surface. Use broad belt.	02																																									
	iv	$F = ma$ $F = 50Kg \times 10ms^{-2}$ $F = 500N$	02																																									
	v	$500N \times 5m = 250Nm$	02																																									
B	i		04																																									
	ii		02																																									
	ii		02																																									
	vi	Pulling the rope or suitable example	02																																									

08															
A	i	<table border="0"> <thead> <tr> <th><u>Feature</u></th> <th><u>Animals</u></th> </tr> </thead> <tbody> <tr> <td>1</td> <td>Sea anemone</td> </tr> <tr> <td>2</td> <td>Earth worm</td> </tr> <tr> <td>3</td> <td>Cockroach</td> </tr> <tr> <td>4</td> <td>Snail</td> </tr> <tr> <td>5</td> <td>Star Fish</td> </tr> </tbody> </table>	<u>Feature</u>	<u>Animals</u>	1	Sea anemone	2	Earth worm	3	Cockroach	4	Snail	5	Star Fish	05
<u>Feature</u>	<u>Animals</u>														
1	Sea anemone														
2	Earth worm														
3	Cockroach														
4	Snail														
5	Star Fish														
	ii	Invertebrates	01												
	iii	Arthropoda, Echinodermata	02												
	iv	Sea anemone	01												
	v	Snail	01												
B	i	When increasing the current potential difference is increased.	02												
	ii	$V = IR$ $5 = 1 \times 10$ $I = 5/10 = 0.5 \text{ A}$	02												
	iii	Temperature	01												
	iv		02												
	v	13	01												
09															
A	i	$40/5 = 8\text{ms}$	02												
	ii	600m	03												
	iii	$600/15 = 40\text{ms}^{-1}$	03												
	iv	Uniform velocity	02												
B	i	Second period iv Group	02												
	ii	$x = 1 \quad y = 4 \quad z = 1$	03												
	iii	Proticem , Deuterium , Tritium	03												
	iv	Ionic	01												
	v	Covalent	01												